

||||||| ROTARY BARRELS – MODEL RANGE A |||||||



TROWAL SURFACE FINISHING

Rotary mass finishing barrels – model range A

APPLICATIONS

Rotary barrels generate the most gentle media/part movement among the different types of mass finishing equipment. Subsequently, rotary barrels produce extremely smooth surface finishes with finely radiused edges. They are ideal for processing small to midsize batches of parts requiring an excellent finish with low R_a readings. Of course, rotary barrels are also ideally suited for high gloss polishing.

THAT'S HOW ROTARY BARRELS WORK

The special double cone octagonal shape of the rotary barrel generates a three-directional movement of the media and parts. Since the parts in the barrel are not tumbling but only sliding over each other, the process is very gentle without severe part-on-part contact and no risk of part nicking whatsoever. The process intensity can be regulated with different rotary speeds within a range of 2–30 RPM and the tilting angle of the barrel. The media and parts are manually loaded. For easy unloading of a finished batch the barrel is electro-mechanically tilted downwards. Generally, the cycle times in rotary barrels are somewhat longer compared to vibratory finishing systems.

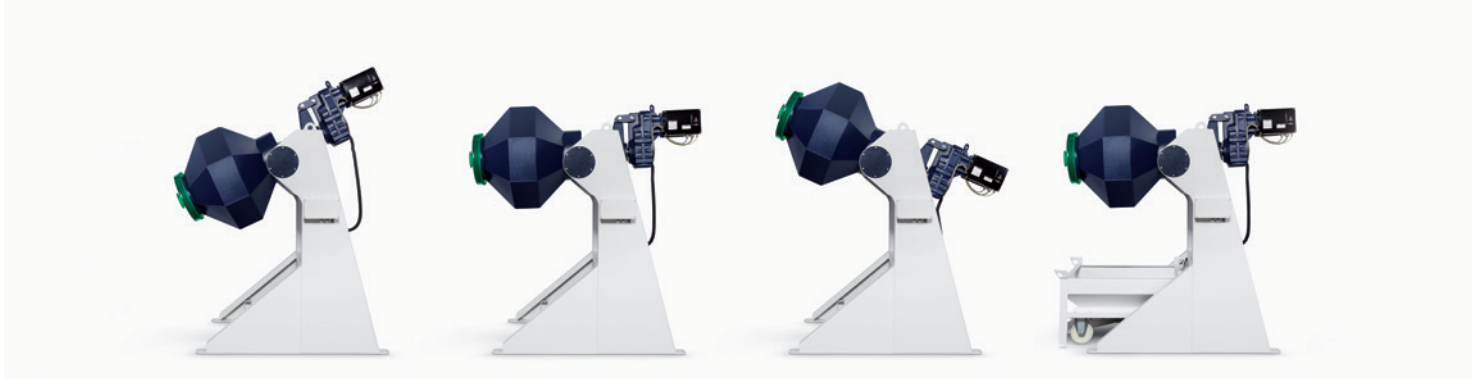

	A 65	A 110	A 150	A 220
Usable volume of parts and media (L)*	30	50	70	100
Thickness of barrel lining (mm)	8	8	8	8
Drive power (kW)	1,5	1,5	1,5	1,5
Rotational barrel speed (RPM)	2-30	2-30	2-30	2-30
Total weight, empty (kg)	425	445	460	480
Max. work piece dimension (mm)**	120	200	200	250

*Ratio of media to work pieces normally 3:1, i.e. 3 parts of media to 1 part of work pieces

**Parts must be smaller than the barrel opening. Rotary barrels are primarily used for processing of small, mass-produced parts

	A 65	A 110	A 150	A 220
A	1,285	1,285	1,285	1,285
B	1,350	1,460	1,550	1,610
C	1,670	1,750	1,790	1,860
D	2,090	2,090	2,090	2,090
E	720	630	570	500
F	900	900	900	900
G	1,110	1,110	1,110	1,110
H	1,400	1,400	1,400	1,400
I	1,050	1,050	1,050	1,050

Dimensions in mm

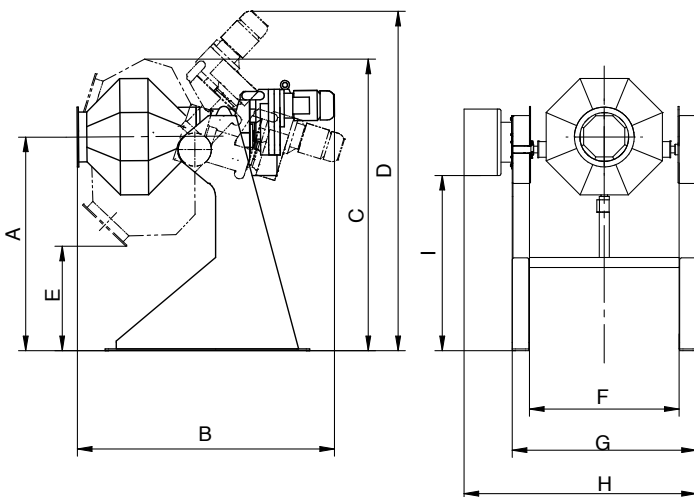

TECHNICAL HIGHLIGHTS

- Barrel drive: Flat gear motor with attached frequency inverter
- Barrel: Sturdy double cone octagonal weldment
- Wear protection: Barrel lined with wear resistant rubber
- Tightly fitting, lockable safety lid made from polyurethane with integrated Walther quick connect coupling for attaching a rinse water hose

BARREL TILTING SYSTEM

- Electro mechanical linear drive with trapezoidal screw. The lifting/lowering speed of 9 mm/sec allows quick loading & unloading of part/media batches. Especially advantageous in the case of short processing times, or when multiple barrels must be operated by one operator.



**WALTHER
TROWAL!**

Walther Trowal, LLC

4540 East Paris Ave SE, Ste F | Grand Rapids, MI 49512

Tel. +1 (616) 455-8940 | Fax +1 (616) 871-0037

info@walther-trowal.com | https://walthertrowal.com/